

MQ1350B 外圆磨床

Cylindrical Grinder

用途与特征

- MQ1350B外圆磨床适用于磨削圆柱形或圆锥形回转体工件的外圆表面，用于单件小批量生产的场合。
- 机床工作台的纵向移动可由液压无级变速传动，也可用手轮传动。
- 砂轮架横向进给可由液压作微量自动周期进给和快速进退，也可用手轮实现粗细两种进给。
- 砂轮架和工作台导轨采用静压润滑。
- 砂轮主轴由三块扇形轴瓦支撑。
- 工件、砂轮、液压泵、冷却泵分别由独立电机驱动。
- 机床各运动部件具有电器，液压和机械连锁机构，操作安全可靠。

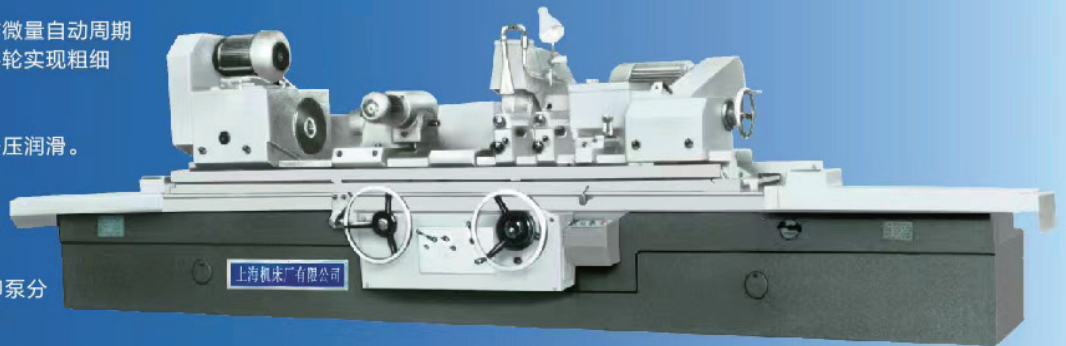

Main Application and Features

- MQ1350B Cylindrical Grinder is designed for grinding cylindrical or taper surface of rotational parts. It is highly adaptable for single and small batch production.
- The table traverse is actuated by hydraulic means at infinitely variable speed or operated by hand.
- Auto intermittent micro-feed and rapid approach and withdrawal of the wheelhead can be effected hydraulically; while rough-fine-feed realized by handwheel.
- The worktable and wheelhead guideways are hydrostatically lubricated.
- The grinding wheel spindle is supported by three tilting segmented shoes.
- Workpiece, wheel, hydraulic pump, coolant pump, are driven separately by individual motors.
- Each motion part of the grinder is controlled by electric, hydraulic, mechanical interlocking mechanism, thus the grinder can be operated with ease and safety.

MQ1350B 外圆磨床 Cylindrical Grinder

规格及主要技术参数

Main Specifications

可磨最大直径	Max. dia. to be ground	500mm
可磨最大工件长度	Max. length to be ground	1000,1500,2000,3000,4000mm
最大工件重量	Max. workpiece weight	1000,2000,2000,2000,2000kg
砂轮尺寸 (外径×宽×内径)	Wheel size (O.D. X W X I.D.)	Φ750×75×Φ305mm
砂轮主轴转速	Wheel spindle rotation speed	886r/min
中心高	Center height	270mm
工作台最大移动量	Max. worktable traverse	1000,1500,2000,3000,4000mm
工作台最大移动速度	Max. worktable travel speed	3m/min
砂轮线速度	Wheel peripheral speed	35m/s
砂轮架快速进退量	Wheelhead rapid approach and withdrawal travel	100mm
自动周期进给量 (粗/细)	Automatic intermittent infeed (coarse/fine)	0.02/0.0025mm
手动微量进给量 (粗/细)	Manual microfeed (coarse/fine)	0.02/0.0025mm
油泵排量	Hydraulic pump displacement	16ml/r
油泵压力	Hydraulic pump pressure	6.3MPa
冷却液流量	Coolant flow	50L/min
电机总功率	Total motor power	20.63kW
砂轮电机功率	Wheelhead motor power	15kW
外形尺寸 (长×宽×高)	Overall dimensions(L×W×H)	(1000)5070×2140×1550mm (1500)5320×2140×1550mm (2000)6090×2140×1550mm (3000)10240×2140×1550mm (4000)12280×2140×1550mm

工作精度

Working Accuracy

圆度	0.0015mm/0.0025mm
Roundness	
纵截面内直径的一致性	0.008mm/0.012mm
Dia. uniformity in the long. section	
表面粗糙度	Ra0.16 μm
Surface roughness	

主要附件

Main Accessories

冷却设备	1套set
Coolant equipment	
砂轮外圆修整器	1套set
Wheel periphery dresser	
砂轮法兰	2件pcs
Wheel hub	
砂轮平衡轴	1件pc
Wheel balancing-mandrel	
机床垫铁 (可磨长度)	12/12/18/22套sets
Leveling wedge (length to be ground)	
(1500/2000/3000/4000mm)	

特殊附件

Special Accessories

砂轮平衡架	1件pc
Wheel balancing stand	
磁性分离器	1件pc
Magnetic separator	
镶块顶尖	2件pcs
Carbide tipped center	
磨顶尖装置	1件pc
Center grinding attachment	
开式中心架 (可磨长度)	1/2/3件pcs
Open-type steady-rest (length to be ground)	
(1500/2000/3000mm)	

上海机床厂有限公司市场营销部 Shanghai Machine Tool Works Ltd Marketing Department

内销 Domestic Section

电话 (Tel) : 021-55228502

售后服务: 021-65494608

传真 (Fax) : 021-65340757

邮箱 (E-mail) : smtw-sales@smtw.com

外销 Export Section

电话 (Tel) : +86-21-65496364、65517713

传真 (Fax) : +86-21-65340757 邮箱 (E-mail) : info@smtw.com

由于技术不断发展, 本样本仅供参考 具体参数与配置以签订的合同为准 2022年9月
Considering continuous development of technology, above information is for reference only.