



AIR COOLED HEAT EXCHANGER



Shanghai Electric-SPX Engineering & Technologies Co., Ltd.

3F, Building C, No.621 Long Chang Road, Yangpu District, Shanghai, China (200090)

Tel: +86 21 6070 3766 Fax: +86 21 6070 3858

Suite 8F, Tower B, Gateway Plaza, No. 18 Xia Guang Li, North Road,

East 3rd Ring, Chao Yang District, Beijing, China (100027)

Tel: +86 10 5608 2100 Fax: +86 10 5608 2130



CONTENTS

Company Introduction	01
Technology Origins and Application Areas	02
Introduction of Company Products	03
Air Cooled Heat Exchanger (ACHE)	05
Heat Transfer Types	
Air Cooler Structure	
Finned Tube	
Header	
Air Cooled Condenser (ACC)	11
Single Row Tube	
Structural Layout	
Mechanical Draft Cooling Technology (MDCT)	15
R&D and Technology	16
Production Bases (Qualification)	17
Typical References	19



COMPANY INTRODUCTION

Shanghai Electric is one of the largest integrated equipment manufacturing groups in China. Its leading industries focus on energy equipment, industrial equipment and related services. Relying on the overall advantages of clean and efficient product technology, it provides users around the world with targeted comprehensive solutions for clean energy.

Shanghai Electric - SPX Engineering & Technologies Co., Ltd ("SEC-SPX" for short) is a strategic joint venture between Shanghai Electric Group Co., Ltd. and SPX Corporation, affiliated with Shanghai Electric Power Generation Group. SEC-SPX is dedicated to supplying advanced air cooling systems for power and petrochemical plants in China and select global opportunities.

SPX is the global leader in innovative solutions for power plant cooling systems. SEC-SPX, formed in December 2011, is based in Shanghai with a branch office located in Beijing. Upon its establishment, SEC-SPX possesses all SPX's air cooling technologies, references and patents and shares the latest SPX European air cooling technology and scientific research achievements.

The air-cooled products of SEC-SPX are widely used in coal-fired power plants, coal chemical industry, petrochemical industry and other fields, as well as in new energy markets such as CSP, biomass, geothermal, combined cycle and so on. SEC-SPX's air cooling technology can meet the needs of the owners to the greatest extent, and can provide financing, leasing and other business cooperation modes.

At present, SPX air cooling has nearly 1,000 air cooling projects in the world and more than 100 in the Chinese market.

TECHNOLOGY ORIGINS

SEC-SPX's air cooling technologies originate from Balcke-Dürr and air cooling sector of Hamon which were acquired by SPX in 2002 and 2003 respectively. Based on the century long history of air cooling technology research and development by the two brands, SPX now owns 25 global patents and is a global leader in developing innovative cooling solutions for power stations.

After the establishment of SEC-SPX in 2011, SPX transfers all its air cooling technologies and patents into the joint venture. Meanwhile, the joint venture houses an R&D center in Shanghai to be synchronized with the technology advancement developed by SPX's European air cooling technology center. Thus SEC-SPX is ensured with the latest world-leading technologies.

In 2016, SPX's air cooling business was transferred to Paharpur Group, and the European parent company of the joint venture was renamed SPX Dry Cooling.

APPLICATION AREAS

Oil refining, coal to oil, methanol, natural gas to oil, petrochemical, coal chemical, natural gas pipeline transportation, combined cycle power station, cogeneration of heat and power, thermal power, CSP, biomass power generation, etc.



Air-cooled Heat Exchanger Products

Air Cooled Heat Exchanger (ACHE)



Air Cooled Condenser (ACC)



Mechanical Draft Cooling Technology (MDCT)

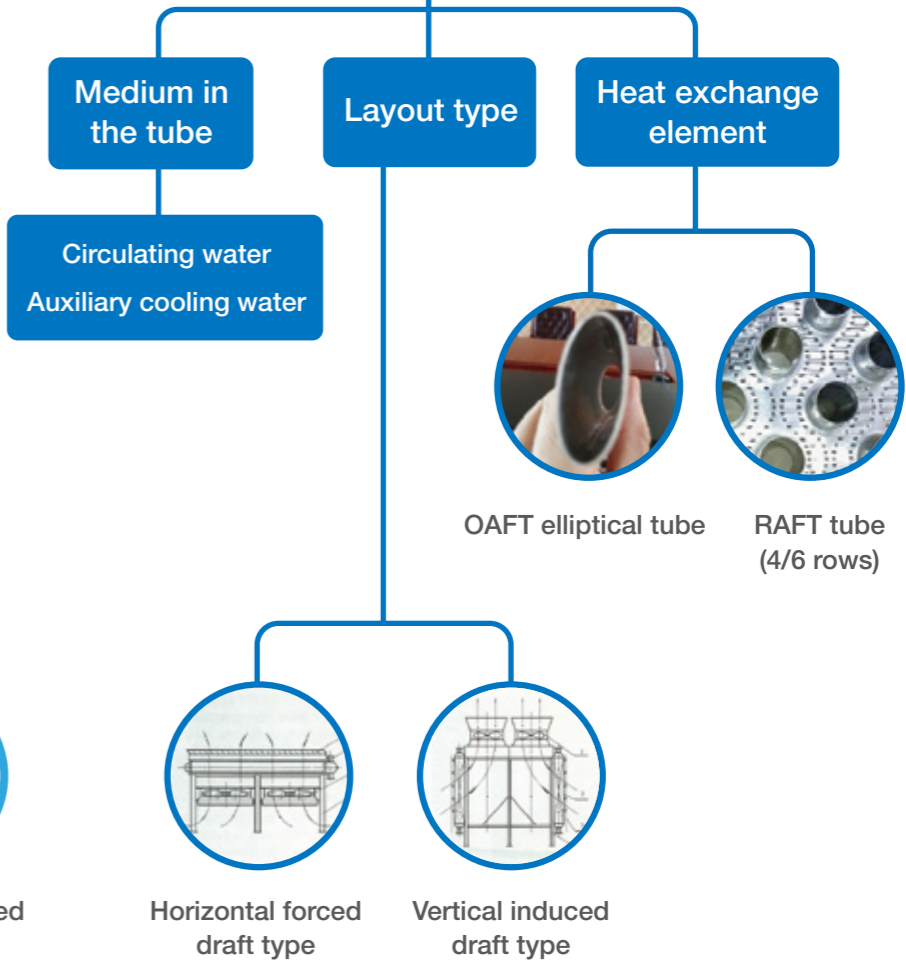
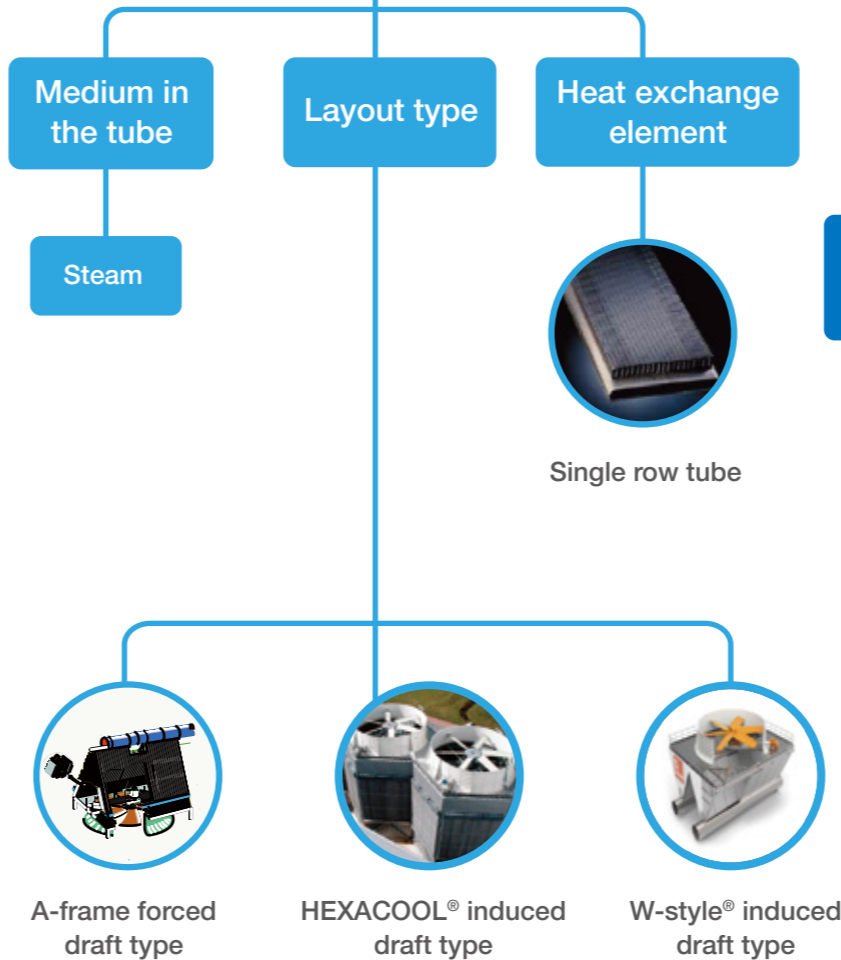
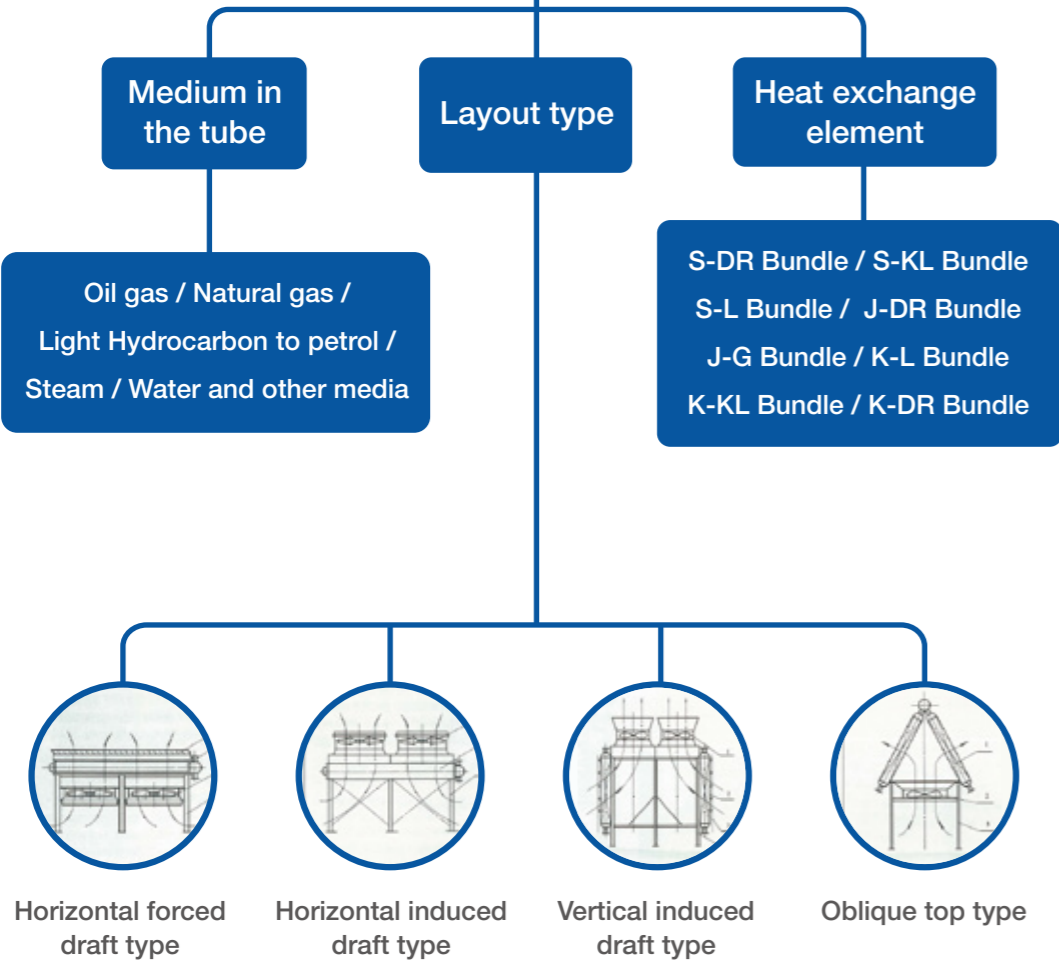

Air Cooled Heat Exchanger (ACHE) HEAT TRANSFER TYPE

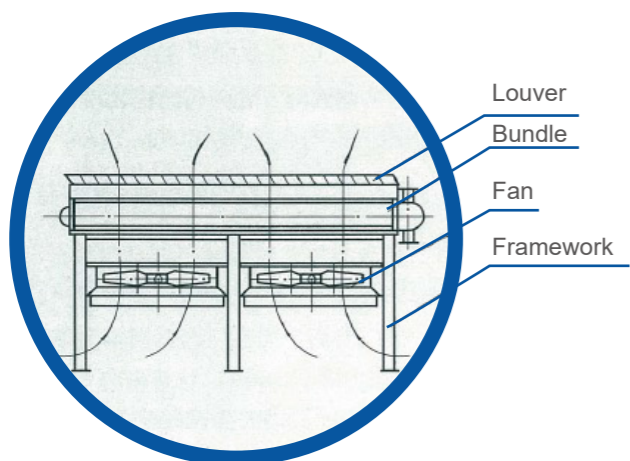

Horizontal air cooler
(forced draft)

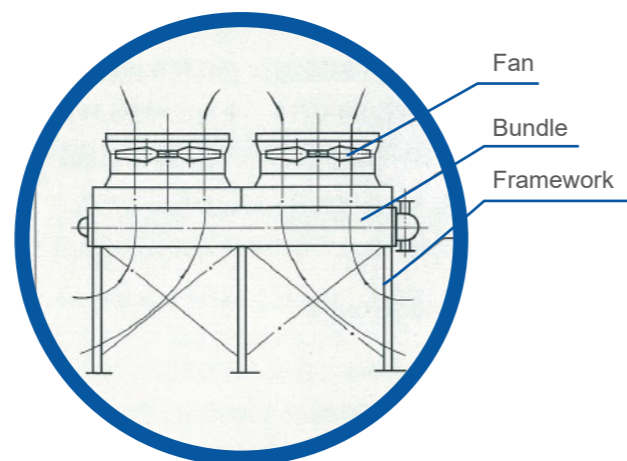

Horizontal air cooler
(induced draft)

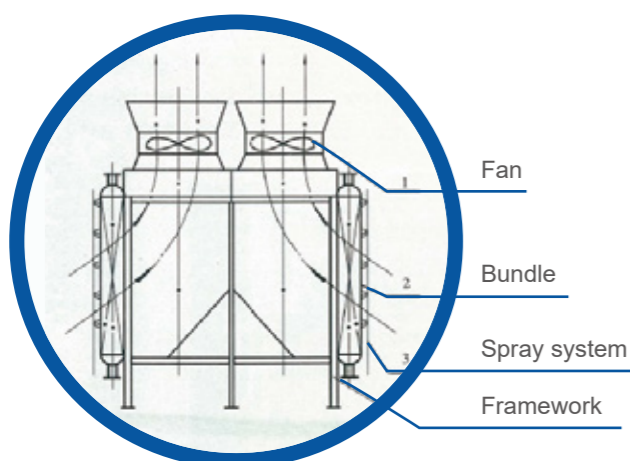

Vertical air cooler
(induced draft)

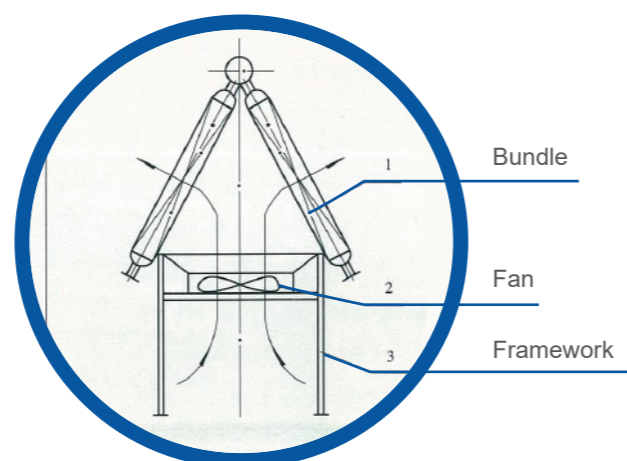

Inclined top air cooler
(forced draft)

Air Cooled Heat Exchanger (ACHE) AIR COOLER STRUCTURE

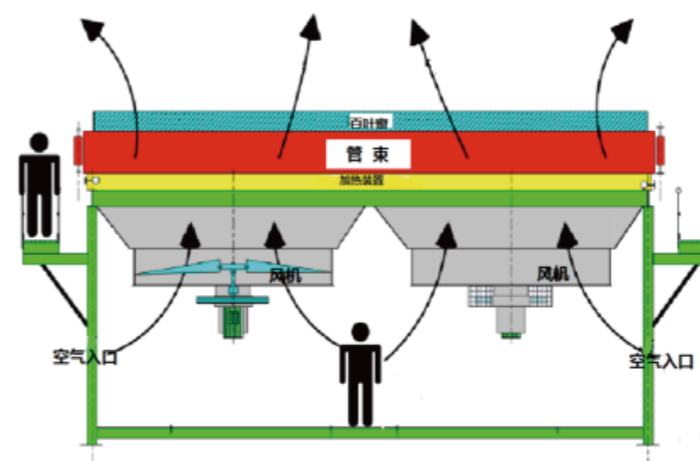

Forced draft type device



Forced draft type



Induced draft type

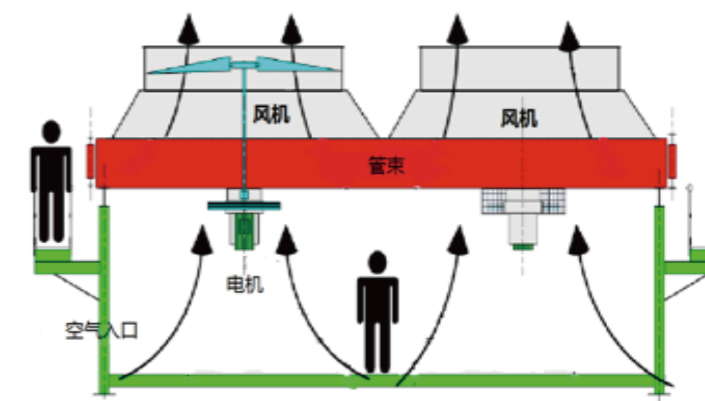

Induced draft type device

Air Cooled Heat Exchanger (ACHE) FIN TUBE

ROUND STEEL TUBE WITH ALUMINUM FINNS

Base tubes are made of carbon steel, low alloy steel and stainless steel, etc.
 Fin-to-tube bonding: L/G/E/KLM/LL, etc
 Among these types, bimetal extruded type and L type are the most used.

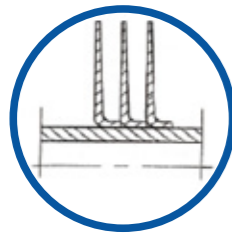
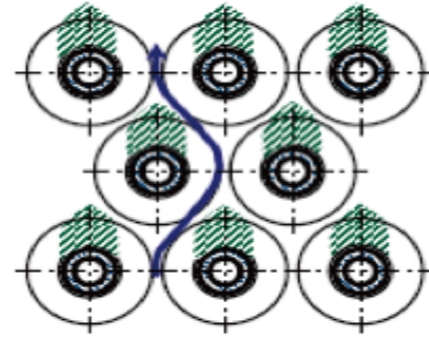

L- type finned tube (L)

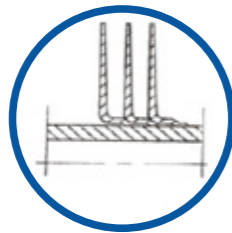

LL-type finned tube (LL)

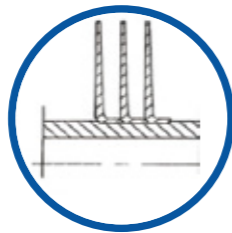



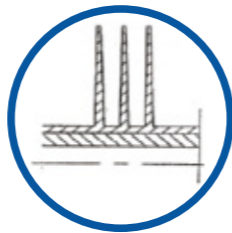

Rolled finned tube (KL)

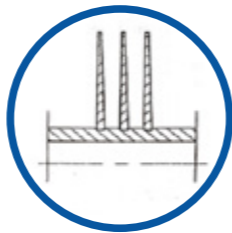

Bimetal extruded finned tube (DR)

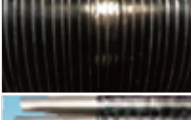

Embedded finned tube (G)

Product	Fin tube type	Maximum operating temperature	Corrosion Resistance	Mechanical properties	Heat transfer performance
	G-type embedded finned tube	400 C	Normal	Good	Good
	Bimetal extruded finned tube	300 C	Excellent	Excellent	Excellent
	KL-type rolled finned tube	250 C	Good	Good	Good
	LL-type finned tube	120 C	Good	Poor	Normal
	L-type finned tube	120 C	Normal	Poor	Normal

Air Cooled Heat Exchanger (ACHE) HEADER

PLUG HEADER

Plug header is one of the most widely used header structures. Its working pressure can reach up to 35 MPa. The plug holes corresponding to each heat exchange tube can be used for expansion, cleaning and leak plugging of tubes and tube sheets.

For high hydrogen partial pressure medium, if sealed welding or strength welding is used, its cost is lower than that of the manifold header of over 20 MPa.

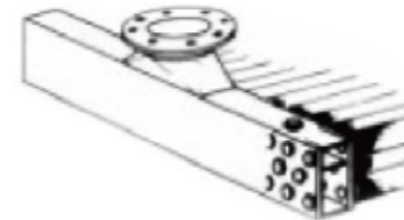

COVER PLATE HEADER

Cover plate header is mainly suitable for high-polluted media with a maximum pressure of no more than 4 MPa and needs frequent cleaning. At the same time, it is also suitable for high-corrosive media and for situations when regular check of corrosion is needed. In hydrocracking plants, a special cover plate header with welded seam gaskets is often used.



D-WELDED HEADER

D-welded header is suitable for high sealing requirement tube bundles, it is of low cost, but inconvenient to clean inside the header, so it is widely used in occasions where scale is not easy to accumulate in the tube.



MANIFOLD HEADER

The manifold header is mainly used in high temperature and high pressure air cooler. It can ensure that poisonous, flammable and other harmful gases and liquids are not leaked. The header structure can be determined according to the user's requirements, and its operating pressure is up to 50 MPa.

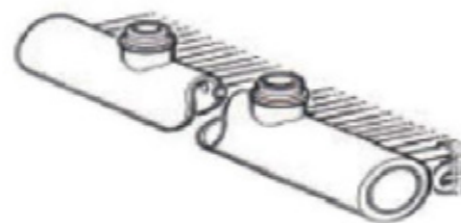

AIR COOLED CONDENSER (ACC)

Air Cooled Condenser (ACC) is a direct air cooling system where the steam is condensed inside finned tubes, and the cooling media air is blowing outside the fin tube. ACC is made of modules arranged in parallel rows. Each module contains a number of fin tube bundles. An axial flow, forced-draft fan located in each module forces the cooling air across the heat exchange area of the fin tubes.

The fin tube is the core technology of the ACC, and the quality of fin tube is the key driver for the performance and life time of the ACC. SPX was the first to apply single-row fin tube technology (SRC®) which is widely used currently in the market and SPX's SRC® technology is mature and reliable.

DESIGN FEATURES OF SINGLE-ROW (SRC®)

The fin tube of single-row fin is an elongated flat aluminum coated carbon steel tube with aluminum fins directly brazed on the tube, ensuring an excellent and long lasting thermal and mechanical bonding between the fins and the tubes.

Features are:

- + High heat exchange efficiency
- + Balanced steam flow, no risk of backflow
- + Low pressure drop at the steam side, low back pressure
- + Small air side resistance, low power consumption
- + Good cleaning capability

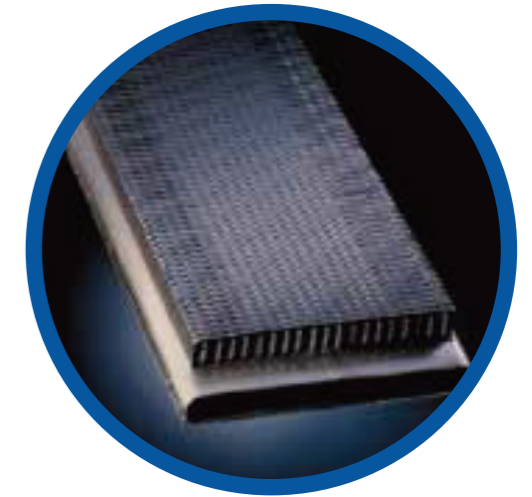

Air Cooled Condenser (ACC) A-FRAME STRUCTURE

A-frame is widely used in mechanical draft air cooled condenser. Up to the end of 2018, SPX has installed more than 800 A-frame ACCs worldwide. Faced with the market demand, SEC-SPX continuously develops and innovates, upgrades the existing A-frame structure, and successively introduces five upgraded characteristic technologies.

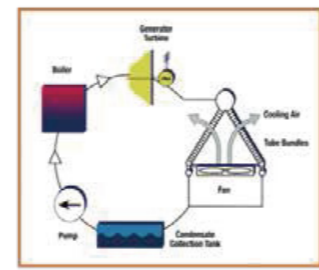
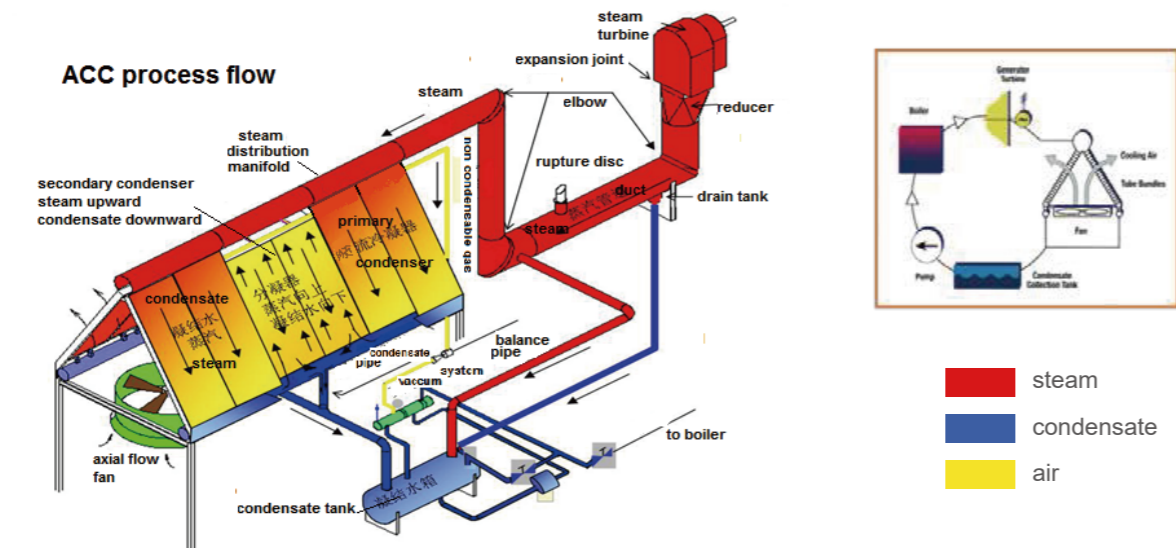

- steam
- condensate
- air

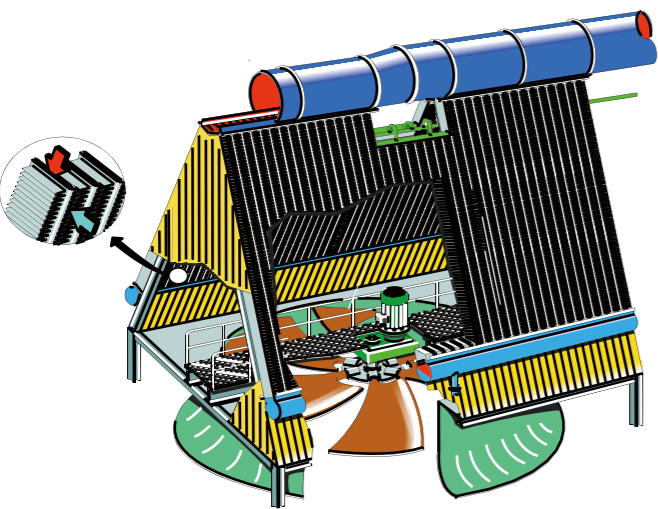

Up gradation



A-FRAME STRUCTURE W-style®

W-style® is an innovative forced draft air-cooled condenser, which upgrades the traditional A-frame arrangement. The bundle arrangement of W-style® greatly reduces the consumption of steel structure. Reducing the length of finned tube can achieve lower back pressure, accelerate the flow rate in the tube, reduce the risk of corrosion, and enhance the anti-freezing ability.



ACC UPGRADING TECHNOLOGY HEXACOOL®

HEXACOOL® is dedicated to small units and is SPX's patented air cooling product, with no water consumption, Particularly applicable to small project.

HEXACOOL® has the following advantages:

- + Flexible arrangement
- + Robust in winter conditions and increase of performances
- + Limited impact of wind on performances
- + Reduced auxiliary power consumption
- + Simplified assembly and reduced construction time
- + Simplified maintenance and inspection of bundles
- + Vertical SRC® bundles
- + Forced draft

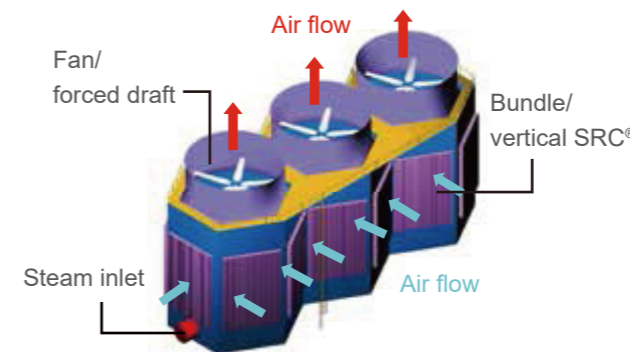

MECHANICAL DRAFT COOLING TECHNOLOGY (MDCT)

MDCT consists of several fan modules, each of which includes several heat exchanger bundles arranged vertically in triangles. The fan is installed at the top of the module. The air is induced by the induced draft fan, passed through the finned tube, and discharged through the air cylinder at the top of the fan.

At present, the common MDCT on the market is round aluminum tube with aluminum fin (RAFT). The RAFT of SEC-SPX can be arranged in four rows and six rows, which can be designed and manufactured according to the actual situation of the power plant.

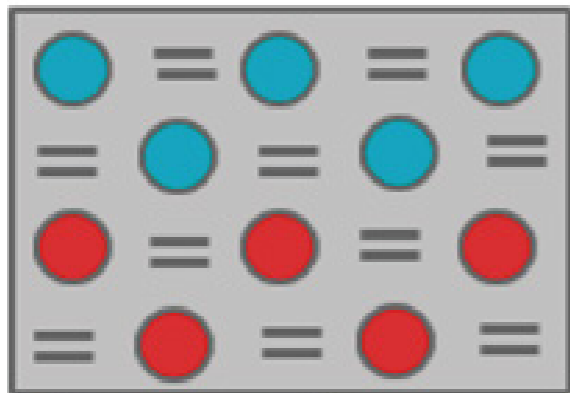

R&D AND TECHNOLOGY

Balcke-Dürr, Germany, has nearly 200 years of professional and technical experience in air-cooled heat exchangers and is an international leader in the field of heat transfer technology. In 1995, Balcke-Dürr established a production base in Zhangjiakou. Eighty-five percent of the air-cooled heat exchangers manufactured are exported overseas and 15% are sold in China, ranking the top three in the domestic market share.

The company has a complete set of air-cooled heat exchanger design software, and has a R&D center in Shanghai, to ensure that the products are safe and reliable, to meet customers' all-round, multi-level requirements.

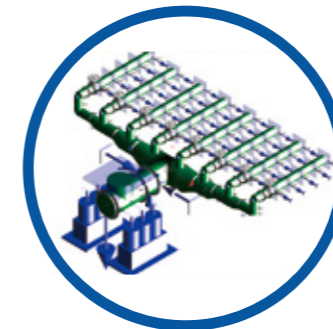

AUTOPIPE

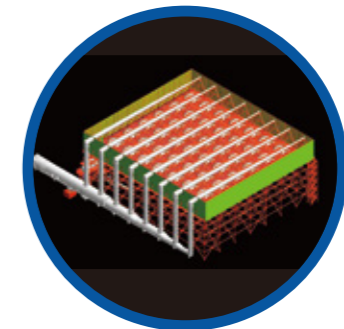

PDMS

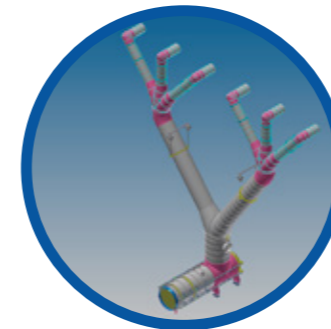

INVENTOR

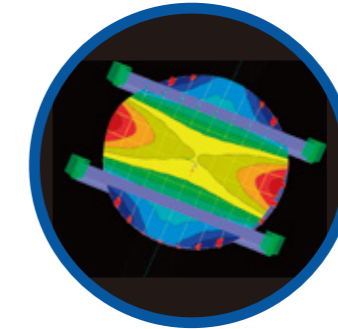

RFEM

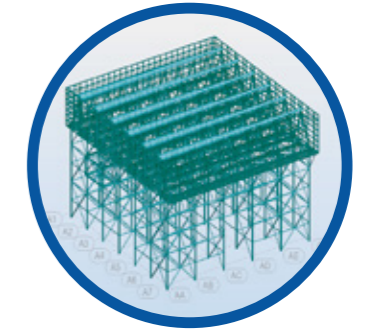

ROBOT

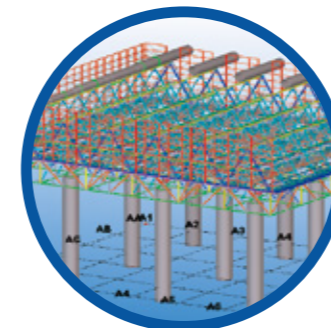

TEKLA

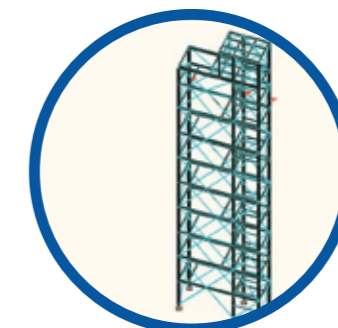

STAAD

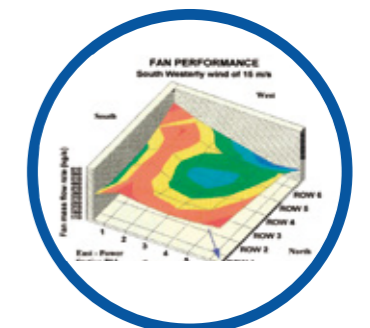

Numerical simulation

PRODUCTION BASE

The production base of SEC-SPX has complete production qualifications and professional technical personnel, rigorous management, self-contained facilities, and can effectively ensure product quality and supply cycle, provide high-quality air-cooled heat exchangers for domestic and foreign users.



QUALIFICATIONS

ASME "S" and "U" Stamp Certificates
 NB Stamp of American Association of Boiler and Pressure Vessel Inspectors
 Certification of German Boiler and Pressure Vessel and Its Accessories Manufacturing Plant AD-Merkblatt HP 0/TRD201



Design and Manufacture License for Class I II III Pressure Vessels in China



ISO 9001 Quality Management System Certificate
 ISO14001 Environmental Management System Certificate
 OHSAS 18001 Occupational Health and Safety Management System Certificate



LIST OF MAJOR CUSTOMERS



TYPICAL REFERENCES



Coal-derived Natural Gas Project II, Inner Mongolia Huineng Coal Chemical Co., Ltd.



High pressure Air Cooler for ANOKYI Mainline Compressor Station (AMCS) EPCC Project, Ghana



Sinopec Zhenhai Refinery Turbine ACC



Air cooler of Shanghai Jinshan Petrochemical Aromatics Plant



Continuous Reforming Unit of Lanzhou Refinery



Air cooler of Yanshan Petrochemical p-xylene plant



Sinopec Yanshan Petrochemical p-xylene Plant

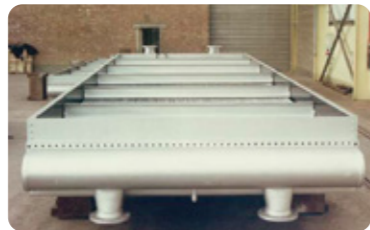

600,000 t/a air cooler for SINOPEC Lanzhou Refinery and Chemical Alkylbenzene Project



MDCT of Gemeng Chongguang Auxiliary Machine



Italian Combined Cycle Power Plant ACC



Bruges Power Plant with A-frame ACC in Belgium



Bavaro-Rosendall HEXACOOl® project in the Netherlands

Client	Equipment	Medium	Product	Qty.	Pressure MPa	Material
Sinochem Quanzhou Petrochemical Company	Turbine Air Cooler of Reforming Recycle Hydrogen Compressor	steam	ACC	2	0.1	CS
Sinochem Quanzhou Petrochemical Company	Turbine Air Cooler of Reforming Supercharger	steam	ACC	2	0.1	CS
Inner Mongolia Huineng Coal Chemical Co., Ltd.	Propylene from Coal Gas	steam	ACC	4	0.1	CS
Inner Mongolia Huineng Coal Chemical Co., Ltd.	Coal Gas Air Separation Unit	steam	ACC	24	0.1	CS
Inner Mongolia Huineng Coal Chemical Co., Ltd.	Coal Gas Power Station	steam	ACC	8	0.1	CS
Inner Mongolia Huineng Coal Chemical Co., Ltd.	Coal Gas Liquefaction Unit	steam	ACC	9	0.1	CS
Tenglong Aromatics (Zhangzhou) Co., Ltd.	800,000 tons aromatics plant	aromatic hydrocarbon	ACHE	4	1.75	10#/Q345RD
Yanchang Petroleum and Natural Gas in Shaanxi Province	Methanol recovery	methanol	ACHE	1	0.1	10#/Q345RD
Ghana National Oil and Gas Corporation	Natural Gas Pressure Station	High Pressure Natural Gas	ACHE	3	11	SA179
Lopburi Chemical Fiber of Thailand	Polyester fibers	steam	ACHE	2	1.6	SS321
GE Encryo Engineering Technology Co., Ltd.	Natural Gas Pressure Station	High Pressure Natural Gas	ACHE	3	11	SA179
Shandong Kerui Group	Natural Gas Pressure Station	Natural gas	ACHE	3	1	SA179
Kelgary (Beijing) International Oil and Gas	Compressor air cooler	Lubricating oil	ACHE	4	1	
China Construction Sixth Engineering Division Corp. Ltd.	LNG Sewage Treatment	methanol	ACHE	1	0.1	10#/Q345RD
Sinopec Zhenhai Refining and Chemical Company	Air Cooler of Isomerized Cyclic Hydrogen Compressor	steam	ACC	8		CS
Sinopec Shanghai SECCO Petrochemical Company	1 million tons of ethylene	propylene	ACHE	30		CS
Sinopec Yanshan Petrochemical Company	PX device	aromatic hydrocarbon	ACHE	4	0.13	10dg
Sinopec Yanshan Petrochemical Company	PX device	benzenes	ACHE	1	2.56	10dg
Sinopec Jining Petrochemical Company	Syngas unit	steam	ACC	1	1	10dg
Sinopec Jining Petrochemical Company	Fertilizer Plant	steam	ACHE	1	2.5	10dg
Sinopec Jining Petrochemical Company	Sulfur recovery	acid gas	ACHE	2	0.6	0C18N19TI
Sinopec Jining Petrochemical Company	Reforming isomerization	steam	ACC	2	2.5	CS
Sinopec Qilu Petrochemical Company	Catalytic cracking unit	gasoline	AH	10	1	10dg
Sinopec Shanghai Petrochemical Company	Aromatics plant	aromatic hydrocarbon	ACHE	4	3.56	10dg
Sinopec Yanshan Petrochemical Company	Reforming unit	mixed aromatics	ACHE	2	1.6	10dg
Sinopec Changsha Petrochemical Company	Aromatics plant	aromatic hydrocarbon	ACHE	2	1.1	10dg
Sinopec Guangzhou Petrochemical Company	Catalytic device	oil gas	ACHE	3	1.6	CS
Sinopec Guangzhou Petrochemical Company	Atmospheric and vacuum pressure unit	oil gas	ACHE	2	1.3	CS
Sinopec Guangzhou Petrochemical Company	Gas separator	refined propylene	ACC	8	1.6	CS
Sinopec Qilu Petrochemical Company	Raw material pretreatment	sewage	ACHE	6	4	316
PetroChina Urumqi Petrochemical Company	Refinery	steam	AH	7	7	CS
PetroChina Lanzhou Petrochemical Company	Reforming unit	reforming product	ACHE	8	2.5	10dg
PetroChina Lanzhou Petrochemical Company	PX device	p-xylene	ACHE	2	4	10dg
PetroChina Daqing Petrochemical Company	Gas separator	propylene	ACHE	18	1.95	10dg
PetroChina Daqing Petrochemical Company	Gas separator	refined propylene	ACHE	20	2.07	10dg
PetroChina Daqing Petrochemical Company	Gas separator	crude propylene	ACHE	10	3.65	10dg
PetroChina Daqing Petrochemical Company	Atmospheric and vacuum pressure	naphtha	ACHE	10	1	10dg
PetroChina Dushanzi Petrochemical Company	Refining and Chemical Integration	oil gas	ACHE	1	1.6	10AI
PetroChina Dushanzi Petrochemical Company	Refining and Chemical Integration	oil gas	ACHE	1	1.6	10AI
PetroChina Fushun Petrochemical Company	Delayed coking	cold coke water	ACHE	2	2.5	CS
PetroChina Fushun Petrochemical Company	Delayed coking	fractional oil	ACHE	2	1.6	CS
PetroChina Changqing Gas Field	Purification and Liquefaction of Natural Gas	acid gas	AC	4	0.6	SS
PetroChina Changqing Petroleum Exploration Bureau	Purification and Desulfurization of Natural Gas	acid gas	ACHE	2	1	20dg
PetroChina Changqing Petroleum Exploration Bureau	Natural Gas Purification	MDEA	ACHE	2	1	10dg
PetroChina Chongqing Natural Gas Purification Plant	Purification and Liquefaction of Natural Gas	acid gas	AC	3	7.7	CS
CNOOC Petroleum Chemistry Co., Ltd.	Chemical fertilizer	water	Inter cooler	3	1.035	SS
Shanghai Fifth Steel Works, Baosteel Group	Circulating water cooling	condensate	ACHE	3	1	10dg
Yuntianhua Group	Fertilizer Plant	air	AH	5	1.6	10
Sichuan Lutianhua Co., Ltd.	Refined methanol	methanol	AH	3	0.4	10dg
Hangzhou Oxygen Co., Ltd.	Air separation unit	cooling water	ACHE	1	7.7	CuNi
Jiangsu Steel Group	Circulating water cooling	condensate	ACHE	2	0.8	10dg
Shandong Hongxin Chemical Co., Ltd.	Phthalic anhydride plant	xylene	HE	12	1	CS
Foster Wheeler/Jiangsu Dagang Co., Ltd.	Lubricating oil upgrading	lubricating oil	AH	6	3.2	10dg
Alstom/ Waigaoqiao	Circulating water cooling	water	AH	2	2	ASME A214
APEX / USA	IGCC	steam	ACC	120	-1	CS

AIR COOLED HEAT EXCHANGER